

Ad Libitum

A Journal of
THE AMATEUR CHAMBER MUSIC SOCIETY INC.

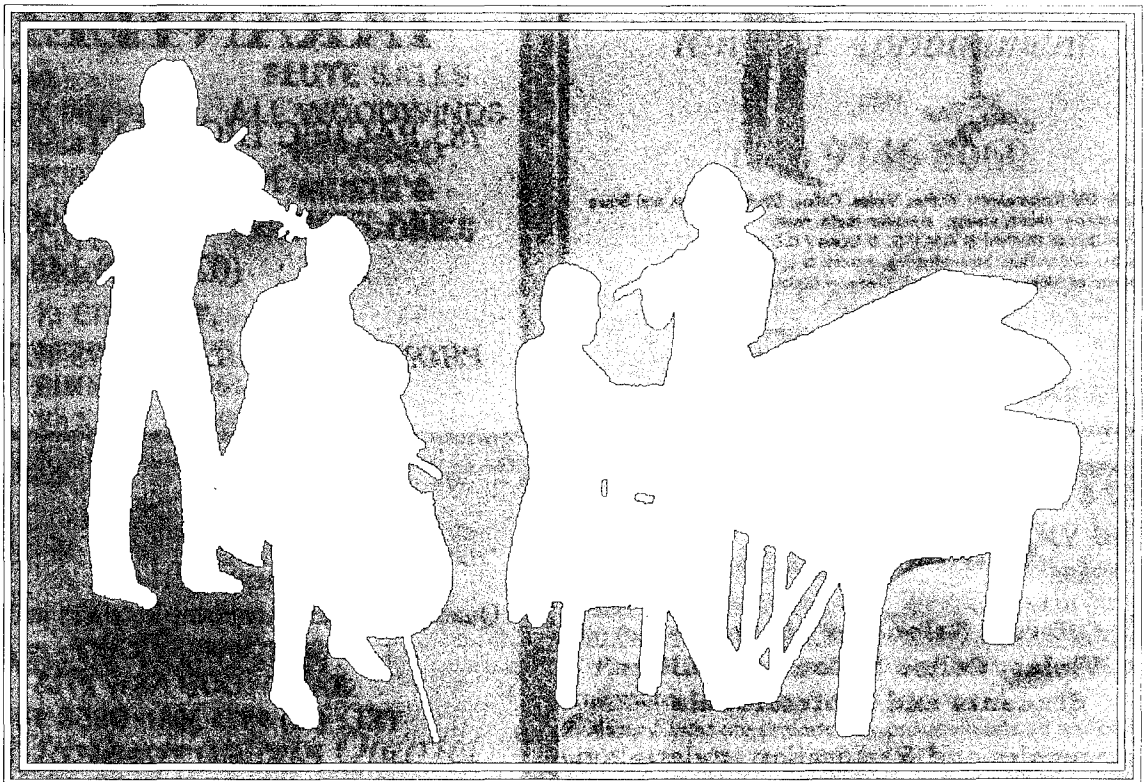

June 1998
Number 3

Published by the Amateur Chamber Music Society Inc.
PO Box 215, Northbridge
NSW 2063 AUSTRALIA

CONTENTS

I Don't Like Modern Music <i>David Mathers</i>	1	Secret Confessions of an ex-President <i>Rod Tuson. Censor: Alexandra Tuson</i>	14
A Traffic Infringement-A Cautionary Tale For Motorists <i>Cedric Ashton</i>	3	Fantasy For Clarinet <i>Carolyn La Motte</i>	16
Lederhosen, Tutors and Tremolo <i>Louis Otonicar</i>	6	Music As A Recreation <i>Solomon Bard</i>	17
Forgotten Piano Quartets <i>James D. Wylie</i>	7	Protect Your Music - Keep It Beautiful ! <i>Peter & Felicia Mitchell</i>	19
The Maligned Pianist <i>Gary Nash</i>	8	Photographs <i>Marjorie Hystek, Ann Korner</i>	5,11,13
The Play Of Daniel <i>Eva Griffith</i>	12		

FOREWORD

Music evokes a rich variety of feelings and responses in those of us who are not tone deaf or victims of irreparable hearing loss from the "Loud" sounds to which some of the young subject their cochleae. Amateurs or professionals, practitioners or listeners, we are inspired, cast down, soothed, moved one way or another. The contributors to this issue of *Ad Libitum* have explored some of these musical reactions. Solomon Bard, quoting J.S. Bach (who better qualified to speak ?) that "*The aim and final reason of all music is the glory of God and the recreation of the mind*" analyses it not only as a recreation in the sense of pastime, entertainment, pleasant occupation, - but also as a re-creation meaning bringing to life the composer's concept. The sense of wonder and awe which comes on us when we thus become, however imperfectly, the vehicle through which the works of the masters are expressed is evoked eloquently by Caroline La Motte. David Mathers confronts us with the shock of being dragged along unfamiliar paths to the challenge of hearing new and often at first unpalatable modern creations - which we may or may not learn to love later. We touch on the competitive, the administrative, even the combative aspects of music making and the fascination of delving into its history.

The musical spectrum has moral dimensions

which deserve to be analysed. At one extreme, overwhelming in quantity and financial rewards, is the world of "popular" and "youth" music which includes hard rock, heavy metal and heaven knows what other devilish sounds and is thus sometimes the backdrop for alienation and drugs. At the other, rarefied, end are the more abstract deconstructed sounds which convey alienation of another kind. Are these polarised manifestations of music the cutting edge or symptoms of a disease? Or even the cause?

Most of us know and love music as a noble art and hardly think that it can be used for degrading purposes. But music can have powerful effects on individual and social behaviour. The Soviets feared a musical break-out from the socialist strait-jacket; the Nazis made use of it to whip up the demons of the master race, the Taliban have banned all music except unaccompanied verses from the Koran. Mercifully we are not confronted with such problems, but we have hardly begun to identify and analyse the pervasive effects of music of one sort or another on our own society. It should make an interesting study.

I would like to warmly thank everyone who sent a contribution to *Ad Libitum*.

Nils Korner - Editor

David Mathers
I Don't Like Modern Music

That's what I like about it !

Forty years ago in the Brisbane City Hall young Mathers was getting his first earful of Stravinsky from the Queensland Symphony Orchestra. Stravinsky's having us on, he thought, it's just noise.

Three dozen years on in the Opera House as the SSO brought Firebird to a brilliant close, not-so-young Mathers said " Ah, you could never go back to Mozart after that."

Modern music is not always easy to like.

Some melodic structures rhythms, chords, cadences... sit easily on the human brain (or maybe just the European brain). This is such stuff as Mozart is made of. And all European music till a hundred years ago. Magnificent stuff much of it, but it's a worked-out vein. Composers can't keep flogging it without being merely imitative. A composer with any intellectual integrity must turn from these well trodden tracks and find other ways to the human mind.

And any music-lover worth.... But enough, lest I upset the old troglodytes still stuck in the comfortable tum-de-tum of last century.. Best stick to my own climb out of the cave.

I had a misspent youth as a flute player. One night I put up a Mozart concerto. "This is going to be my thing " I said, "I'm going to heat the bejabers out of this till I get it right."

In the right hands the outer movements of Mozart flute concertos have a sparkling champagne quality. When you come to work on them, you find the sparkles are made up of hundreds of little semiquavers laid end to end in relentless dayat-dut-dah bar after bar after line after page after repetition after... till you you're damn near screaming. And nowhere near getting it right. Mozart was not for me. What, I wondered, was ?

Awakening musical awareness was like awakening sexuality — all talk and nothing I could get my hands on (this was the early sixties). A mate told me about twelve-tone music. Wow ! That 's interesting - I wonder what it sounds like. Then I went home to the same old warhorses on the wireless, the same baroque on my music stand. And felt cheated. I knew the how and why of twelve-tone, but do you think I could lay my ears to any of it ? Let alone my lips and fingers .

When I discovered *Preamble* in Gordon Jacob : *Five Pieces for solo clarinet* it was like Here at last was this exciting concept coming to life with my own breath.

Another early experience was Richard Hervig : *Divertissement No. 2. Seventy-eight duets for flute and clarinet* (ed. Voxman). Eva and I played it at Clarinet Society one night.

Someone said, "But what does it mean ?" I should have said, "What does Mozart mean ?"

Music is an abstract art form. It doesn't have to mean anything beyond itself. (Stay tuned-- the emancipation of music-- coming soon to a page near you).

Meanwhile, back in Brisbane

I was beating my brain against the neat regular polite music of yesteryear. When I came up for air I went bush. The Australian bush is not neat, regular or polite.

So there I was, camped on a spur of the MacPherson Range after a hard day's walk — dark shapes of trees around me, stars above. Staring into my campfire. Contemplating the chasm between the world I was in and the one that produced my music. Mozart inhabited a world of formal palaces and courtly manners. He wore a powdered wig and a velvet gown and wrote elegant cultured music. What might he have

written if he had spent a day in the Lamington National Park and relaxed beside a campfire ? I felt a tension that needed the resolution of music reflecting the other things I loved.

Ross Edwards once lived beside a National Park on the Central Coast. His music celebrates the natural world of the east coast of Australia. I know where he's coming from.

Maybe music is my bushwalk of the mind — taking risks, pushing into unknown territory. And scorning the cautious tut-tuts of those who stay in the security of their lounge rooms (my maiden aunt was always on about snakes).

The history of music has been an adventure, a breakout from the bonds of song and dance, a handmaiden to other arts fighting for recognition in her own right. Music has become an end in itself. You don't dance to it, march to it, tell a story, praise your god or drink to it. You sit down, shut up and bloody well listen to it. It's been freed from the demand for singable tunes and danceable rhythms. (Where music and everything else is least liberated, music has to be most singable. As Stalin said to Shostakovich.)

If modern music had a definite beginning it was Debussy's *L'Après-midi d'un Faune* in 1894 (see Griffiths, P. *A Concise History of Modern Music*). But it really got going after the First World War. Shocked by the carnage intellectuals rejected (or at least questioned) the conventional wisdom that had gone before. And the music which had been its expression. They looked back to earlier times (neo-classicism). They looked to other cultures (Milhaud, Stravinsky.....discovered jazz). They took a new look at ideas that had been lurking under the overlay of late Romanticism since Debussy.

And they experimented. Unfettered to song and dance anything could happen. This was revolution. All before was evolution. Lots of trials. Lots of errors ? What's an error ? Certainly lots of stuff that's going to go down the plughole of history. But the possibilities are exciting. Nobody will like it all.

They're not meant to like it. Not in the way Haydn humbly strove to delight an aristocratic master. He once gave Esterhazy a gentle nudge for better conditions, but at all other times was anxious to please. When the SSO played John Corigliano (7 Feb. '97), there were no humble servants. Middle-class musicians played for a middle-class audience. John Corigliano wasn't respectfully trying to amuse a bored princeling, he was confronting us with his grief and anger at the death of his friends. Music's come a long way from the pretty titillations of eighteenth century courts. This is communication between equals.

I once visited art galleries. Lots of traditional art. That's nice, now moving right along ... Lots of modern art and I came out wondering what was art anyway what else were the poor buggers to do when the camera put them out of business. You may not like it, but as long as you don't reject it out of hand, you're in for some interesting internal dialogues.

I came away from Wollongong '97 wondering why Milhaud would chuck two good fugues together and come up with chaos.* (Now it's on record. And maybe in another forty years *Aspen Serenade* will be my new oh... wow !)

People don't like modern music. I can relate to that. It was, after all, where I came in. But I came back for a second look and ended up... sometimes excited, sometimes challenged, often completely confused. Always curious. A moment of aroused curiosity is worth an acre of inoffensive wallpaper. Sad so many so-called music-lovers stick religiously to their first opinions, denying themselves the stimulus of new ideas. Music is a living growing artform They treat it like a dead thing in a museum.

** The answer, I think, is he deliberately created confusion, then wrote the trumpet line to take best advantage of the resulting rhythms and harmonies. Only the trumpet is melody. Forget the double fugue-- it's just a device for generating a foundation.*

See, you've got to get something out of an internal dialogue Now I want to hear it again.

A TRAFFIC INFRINGEMENT - A CAUTIONARY TALE FOR MOTORISTS

by Cedric Ashton

The 21st of May is a date I will remember along with one other important date - my wife's birthday, which I dare not forget.

A year or so past I was driving home from the city. It was a nice, sunny afternoon and I'd had a very satisfactory day teaching. Dr Mark Holland was one of my top pupils. As I drove, I mused. I thought how adroitly Mark had negotiated that difficult technical passage in the 1st movement of the Boccherini cello concerto.

Suddenly I was back in the reality of the traffic. There was a slow driver ahead and we drivers caught behind him were endeavouring one by one to weave past him when the oncoming traffic in the two lane highway permitted. Also the hazards of the endless traffic lights brought me constantly back to the reality of the moment.

I passed through Spit Junction, down over the Spit Bridge and through French's Forest. I noted that the spring flowers were out.

Soon I was back on to Pittwater Road at Narrabeen. I was approaching the intersection of Mona Vale Road and Pittwater. The lights were green. I just caught the stack end of the traffic passing as the yellow light clicked on. The next set of lights at the Bayview turn off was on a few hundred yards.

It was green. I pressed my foot down on the accelerator pedal. The light switched to yellow as I sped through. I was elated.

I was rapidly approaching the third and last lights. I was more than 100 yards away when they flicked to yellow. I increased speed to get the hat trick -three in a row. "Whacko!" I shouted. Ten yards from the lights they switched to red. I sped through.

As I did so I briefly caught sight of a police car at the head of a line of cars waiting on my right. My euphoria collapsed like a pricked balloon. Had they seen me ? Would they try to catch me ? Should I turn off at the first bend in the road into a side street ?

These were now my anxious, flickering thoughts. Gone now was the happy driver. I was an animal being hunted.

I decided to make a run for it. This was a stupid decision. Before I reached my turn off at Queens Parade East I saw the police car in my rear mirror, catching up on me fast. On went the siren as he closed in. I pulled over to the gutter. The constable looked in at me.

"Driver, were you aware that you drove through red lights?"

"Yes, but I don't make a practice of it."

"I should hope not. May I see your licence?"

I handed it to him and watched dismally as he made out an infringement notice. He handed it to me with my licence. " Drive carefully, driver, then everyone will benefit."

Smug, righteous bastard, I thought and glanced at the infringement notice. A hundred and thirty five dollars!

That was the first of a series of infringement notices that came in quick succession. On the next occasion, I was speeding through the lights at the corner of Anzac Parade and Cleveland Street. As I did so there was a loud click and a flash of light.

"What the hell was that?" I asked myself. I had encountered my first, recently-installed, camera light; the RTA's latest, devilish invention for apprehending long-suffering motorists like me.

Through experience and succeeding infringement notices, I learned very quickly where they all were situated around the Sydney suburbs. Awaba Street, Drummoyne, General Holmes Drive, etc. With each infringement came a hefty fine and three points marked against me.

On reaching 12 points the Police Traffic Department decided I needed rehabilitating traffic-wise. I had to front up to the local RTA, have my licence marked 'Probational' and pay \$120. I was given a handbook with all the traffic rules. When I had learnt and digested *all* the rules in the traffic manual I then had to submit to a test.

I passed the test and was given two 'P' plates to hang on the front and rear of my car, standing for 'purgatory'.

These two badges I had to display for one year ; they indicated my criminal status. During that year I had to

be extra careful not to lose one point for a traffic infringement. If I did, the Provisional licence would be extended for another six months.

I'll cut this harrowing story short. I did everything by the-book and resisted dashing through yellow lights. It was quite a strain and every time a police car hove in sight, I slowed down to 40 K's.

The last month arrived. First of May, only 21 days to go. I was a nervous wreck and began hallucinating, seeing a policeman on every corner, or police cars appearing...surrounding me...the officers all reaching for their infringement books.

However, I did survive. The 20th May arrived - my last day on probation. I had to conduct the Sutherland Orchestra that evening from 7.30 till 10.30. After the rehearsal I drove from Sutherland to Randwick at 40 km/h, letting every car speed past me.

I arrived at Perouse Street at 11.35pm. It had been so slow driving, I was tired, I was cold, all I wanted to do was to get home to a nice, hot cup of coffee and some toast and happy musing on the next day that my 'P' Plates would be removed.

There was a STOP sign and a white line across the road but there was not a car in SIGHT. I slowed down, but did not quite stop. I cruised slowly across the line.

I hadn't gone 100 yards when I saw in my rear vision mirror headlights switched on. A car started up and was chasing me.

"No, no, it just couldn't be cops," I said to myself. I turned into St Pauls and swung into Daintrey Crescent. I pulled into the curb and was about to step out of my car when a car pulled up alongside me. It was a police car! It was 11:40, only 20 minutes to my release. I was numb with shock.

"Driver, do you realize you went through a STOP sign?"

"Constable, I can't realize anything except that I'm the unluckiest man alive. Ten minutes more and I'd have been out of purgatory."

"Driver, I don't know what you're talking about."

I explained succinctly about losing the 12 points and that I was 10 minutes away from a normal driving status and getting rid of the accursed 'P' plates.

He shook his head. "I'm sorry for you, driver, but you took the risk. You better let me have a look at your

licence."

I nodded resignedly. "Certainly." My expression and voice were woebegone. My world was grey and dismal. I opened the door and the internal light switched on.

On the back seat lay my cello and some orchestral music and my briefcase, containing my licence. The constable had his infringement pad and pen at the ready. He looked with interest at the cello as I fumbled in my brief case for my licence.

"That's a cello, isn't it?"

"Yes."

"Do you play it?"

"I both play and teach it."

"Do you?"

I held out my licence. He took it absentmindedly.

"I've got a daughter of twelve - she's dead keen to learn the cello."

We looked at each other in silence. "That's a good age to start." I tried to sound casual.

"Where do you teach?"

"Here in Randwick and in the city."

"How would I go about getting a cello?" he asked.

"Well, if she wanted me to teach her, I could ask around the various places where I have contacts."

He looked at my licence. "You're Mr Ashton ... of Lovering Place, Newport?"

"Yes."

"It's a far cry from Newport to Randwick. How come you have a teaching studio here?"

I explained that I taught at the Brigidene Convent. Also that I looked after the interests of a certain Miss Ainsworth of 9 Daintrey Crescent, who was 92 and in a nursing home.

The constable put his infringement pad into his breast pocket and took out a small personal notebook. "Mr Ashton, would you be interested in teaching my daughter, Joylene?"

I wanted to shout, "Dear constable, it's what I want to do more than anything else in the world!!"

Instead I said prosaically, "I'll have to look up my engagement book to see if I can fit her in; my book is at Newport."

"Can I phone you?" he asked.

"Sure"

"Your number?"

"99 3378"

"What's your name, Constable?" (Dear reader, you understand why I cannot tell you the constable's true name.)

"Constable ELKIN, my home phone number is....."

I wrote this on a pad.

"Well, I'll have to get back on the beat - and thank you, Mr Ashton."

I smiled. "Thank YOU, Constable."

A week later Joylene Elkin commenced her cello lessons. Like most beginners she was keen, but after two months her enthusiasm evaporated. She discovered that a lot of hard work was required.

She came to her lessons with unprepared work. She had a very faulty sense of pitch, she always arrived late for

her lessons and became rude when corrected. I had exchanged one purgatory for another !

I can hear one reader asking, "Well, what eventually happened ?"

I was contemplating how to inform Constable Elkin, tactfully, that Joylene, the joy of his life, was 'infante orribulis' on the cello, when fate dealt me a kindly blow.

Constable Elkin rang me to say that he'd been posted to a country police station and of course his wife and Joylene went with him.



**Two of our best-loved Tutors
Cedric Ashton - Cello - celebrating his 87th Birthday
Rachel Valler - Piano**

Black & White Photo - Marjorie Hystek

Lederhosen, Tutors and Tremolo

by Louis Otonicar

I remember my first musical experience. It was in 1946. Our school was to be visited by a group of musicians. This would be sponsored by the American occupying forces. What a stir! They would, of course, be Americans playing real instruments like drums and trumpets. Perhaps even Dizzy Gillespie.

The boys were told that Lederhosen would be allowed provided they were less than three generations old. For those unfamiliar with this Austrian garment, they are shorts of stout cardboard-like leather, forged from the hide of the male deer. Because of their indestructibility, they are passed from generation to generation. They are not washable, the theory being that in time they become soft. This process usually takes sixty to seventy years. However, the decrease in hardness is directly proportional to an increase in odour. They were originally designed as a type of birth control. So, on concert day, the gymnasium with four hundred pairs of Lederhosen smelled like a giant urinal.

There was a hushed silence as someone announced the artists. Into the hall walked, not Dizzy Gillespie, but some old men clothed in black and naphthalene. Someone spoke about Brahms. What are Brahms, I wondered. Did I have to be over eighteen to buy it without prescription? Was it for a skin rash?? Eventually they played and did so with grim stoicism.

Sometimes they stared at us boys as if to say, "Vee haf veys to make you enjoy zis music." I wondered how they grew so old. They obviously led wholesome lives and ate vegetables, yoghurt, and molasses. I knew then that music would not be my preferred mode of entertainment.

Half a lifetime later, this view was reinforced on my first playing day on joining the ACMS. The group of players played under the guidance of a tutor. "Are you reading this?" Well, nobody was doing Braille so I guess we were. "Clarinet, you are too loud!!" Although I agreed, I also know that it is easier this way, and that is why the majority don't like to play with clarinetists. Soon

one of the string players seemed to irritate the tutor. "You are in the wrong position!!" Now there is probably no reason why a violin should not be played lying down, but sitting or standing is probably the easiest. "Position! Position!!" The tutor clearly had a more than superficial interest in real estate, or sex, or both. By the time the tutor left we all had a pronounced tremolo without even playing.

The question may be asked, "Why do our tutors address themselves to their task with such seriousness?" The answer is simple. They are professionals and teachers as well, and playing music for a living is a serious matter. They have to get it right the first time or there are no gigs. So, when a tutor is assigned to a room, a few facts are not known. The players are probably meeting for the first time. The music chosen was at random to suit the instrumental combination. One or more members may have taken up learning their instrument at an advanced age. The pianist, having astigmatism, forgot to bring spectacles. Under such circumstances *Verklärte Nacht* may emerge as a giant nightmare. For the players this will probably not pose a problem, but for the tutor it does.

Frequently the players have no intention to achieve achievements, but for a musician / teacher this is probably an unacceptable concept, even if it is only in deference to the composer's venerability. The composer, who, upon accepting a fee had relinquished all rights would not mind a little improvisation on his original theme. Occasionally it has been hinted that there should be a purpose. Why? Is playing amateur music not in itself its own purpose? Or the player's spouse is painting the verandah whilst the other partner is mutilating Mozart.

Eye contact is another suggestion by tutors. This is something we attempt walking down George Street or the Champs-Élysées. Many of us have great difficulty in following the score, let alone exchanging glances. The fact is, for our members in the lower self-evaluation category, the tutors' expectations are too high. If a player cannot

master a phrase or passage after two attempts , chances are that another two months are needed to get it right. Continued persistence results in frustration for the unfortunate offender, and irritation for the other participants.

There is no reason why we should not relate to a tutor what our requirements are. Would the tutor mind if we hobble through the piece, and tell us

afterwards that fingerpainting would be a better hobby. Why not tell a tutor a work is in the exploration stage, and would he / she call out bar numbers and only stop if we are irretrievably lost. As participating members we are committed to make a playing day enjoyable for all.

It is the tutor's obligation too.

Forgotten Piano Quartets

by James D. Wylie

When I was a young man, I was coerced into playing piano in Brahms's Piano Quartet in C minor. Surprisingly, that was in Fiji in the '60s. I doubt if there is still anyone playing chamber music there now. All the musicians I know either left after independence in 1970, or will be playing harps in some beautiful, far off place.

Brahms opened my eyes to the wonders of chamber music. I was led into other fields to milk Trios and even Quintets of their beauty, but somehow always preferred Quartets.

In Rio de Janeiro in 1970, an astute musician, Donna Evangelina, introduced me to a quartet by her father, Arthur Strutt, a composer quite well-known in Brazil then (according to her). It was very Beethovenish, somewhat surprising as it had been written at least a century after the master's death ! The local publishers must have been too nonplussed to publish it, and I remember squinting at a scratchy manuscript with all those wretched reversed-quaver crotchet rests. They still confuse me.

Evangelina's family were all musicians, so we could vary the size of the group, although the quartet always seemed to reappear like a weed in the garden.

Fleeing from Struttomania, I landed in Johannesburg and discovered many good string players there. Soon the other Brahms Quartets, the Schumann, Dvorak, Faure et al succumbed to our rapacious fingers.

One day our violinist, Max, produced a Piano Quartet in A, op. 33, by Richard Franck, a German composer. Max had inherited it from a previous generation in his German family, and insisted we try it. A revelation ! An

excellent work, it was written in the Brahmsian style with slightly more modern harmonies (he was born in 1858), and we enjoyed playing it for a period.

Living on the rim of the South African volcano proved too hot for me and I retired to Australia. The years passed, Max died, and I was able to get another member of the quartet to send me the parts for this quartet. After checking Richard out in the dictionary, I found that his father, Eduard Franck, born in 1819, also in Cologne, was thought to be an even better composer, and wrote a lot of chamber music.

I have written to Germany, and to Peters in London, to trace any works of Eduard's that may still be available, but have had no reply. If anyone can help me, I would be most grateful if they could contact me at the address at the end of this article. I would be interested also to hear if anyone else has a copy of Richard's Quartet (mine is published by Rob. Leinau in Berlin, probably in the early 1900 's). There is no recording of it, nor of anything by his father, except a 'cello sonata.

Another composer whose chamber music seems to have fallen into unjustified neglect is Joseph Jongen, a Belgian composer living in the first half of this century. His Piano Quartet op. 23 in E flat is an interesting composition, and again has not been recorded. There must be lots of other almost unknown quartets of value scattered around the place, and I would be most interested to hear from anyone who has one (or more !). I await with anticipation !

*Jim Wylie, 11 President Poincare Parade, Tanilba Bay, Port Stephens, NSW 2319, Australia
Tel. 02-4982 4886.*

THE MALIGNED PIANIST

by Gary Nash

This article is dedicated to the maligned chamber music pianists of the world. Let us hope that some of the experience and advice contained herein will arm pianists with the necessary confidence and ammunition to fight off the constant abuse heaped on them by uninformed and jealous string or wind players and the like.

We = pianists, *they* = the rest

The supreme instrument

George Bernard Shaw said: "The piano is the most important instrument. Its invention was to music what the printing press was to poetry." Well spoken, George!

We pianists are lucky - we did select the right instrument. It is a wonderful, complete music-making machine, with a tremendous range of colour and dynamics, and not needing the participation of other instruments to make beautiful music. *We* pianists are quite self-sufficient, thank you. The piano repertoire is huge, and many times larger than the entire chamber music repertoire. A solo piano is very pleasing to the ear, as opposed to a solo whatever-else. Of course, this fact creates immense jealousy among the "incomplete" instruments. *We* must be conscious of this if *we* are to understand some of the motivation behind the malignant attitude of some of our fellow musicians.

They will often refer to us as the "Percussion". Well, the "Scrapers" and "Blowers" are right. The hammers do strike the strings. But what a delight that, when *we* place our finger on a key, the sound that comes out is what it should be - not just a vague approximation of the note, patched up by excessive vibrato to make it sound half decent. And, whatever you do, do not fall for this "Equal Temperament" talk from them - quoting "Equal Temperament" does not give them the right to play out of tune.

Of course, the piano is not perfect - *we* all wish it had more sustaining power, that it could crescendo within a chord, that it could have as much singing ability as a string instrument. But then the inadequacies of the other instruments are far greater. Would you want to study an instrument that can only play one note at a time (the winds), or cause the player heart palpitations when double stopping is called for (the strings) ?

But what *we* derive most satisfaction from is the fact that, in between chamber music dates, *we* can make music at home which is satisfying and complete, and not in need of any support from others - and maybe even tolerable to the neighbours. Can they make this claim?

Only with deaf neighbours!

So the bottom line is - *we* play a superior, glorious, "complete" instrument. *We* don't need them, but *they* do need us. Remember that! .

Typical, unjustified criticisms

The single most prevalent criticism levelled at us is that *we* play too loud. Sure, sometimes the criticism is justified. This is especially true for those of us who have just moved to the chamber music scene - when *we* are suddenly not alone any more, but have to listen carefully to our partners and balance our sound accordingly. At all times *we* have to be conscious of the carrying power of the individual instruments, and of the register or range they are playing in, and adjust our dynamics accordingly to produce the proper balance. In the initial stages of a pianist's entry into the chamber music scene, constructive criticism from *them* is indeed of benefit.

But much of the criticism from them suggests that some of them would prefer not to hear the piano at all - or perhaps hear it as a slight murmur in the background to remind them of what key *they* are in, or to keep them more or less in tune, or to provide the basic rhythm, but not much more. When listening to a perfectly balanced recording or performance, *they* will inevitably think it favouring the piano. Why? Because when *they* practice their one-line parts, they do not generally hear in their mind the piano part (or any other part for that matter). Thus, the presence of the piano sound in a recording unbalances their perception of the sound of the work. They tend to be totally focussed on their own part as opposed to the total sound, and if anything interferes with them hearing their own instrument, they are unhappy. Yet *we*, when studying the work, have the complete score in front of us, and that makes us totally conscious of what else is going on besides our own parts. *We* can and do visualise, aurally, the final combined sound - as the composer intended..

We pianists have difficulty in comprehending how *we* could possibly study our part without knowing what else is happening at the time. The end result of the "one-line"

vision is that each of them feels that their part is the most important one at the time they are playing. It reminds me of the opening of the play "Double Bass", where Henry Szeps is heard humming the double bass part of Brahms' First Symphony, oblivious of where the melodic action is.

So the end result is that the first violin, or the flute or the clarinet always believe that, whenever *they* are playing, it must be very important to have their part heard clearly above the others. On the other hand, the instruments which are less likely to have the melody, say the viola or the bassoon, get all excited when something approximating a melody is found in their part, and *they* go flat out to make sure their utterings are very audible indeed. All these quirks unbalance the performance, and cause everyone to play louder (or, heaven forbid, I may not be heard above the racket!).

Back to the point about scores vs one-liners. It is most unfortunate that music publishers give the complete score to the piano only. I know that it would be an extra expense to have four scores for a piano quartet, but I think that it would at least be prudent to include miniature scores for the non-piano instruments as a part of the set. I cannot understand how a player can learn a piece of chamber music (when I say "learn", I do not just mean the notes, but the interrelationship of the parts) without having constant access to the score. And the additional puzzle to me always is that none of them ever ask to look at the score. For self-protection, and in the interests of a better end result, I always make a reduced size copy of the score for each of the members of the group when we are studying a work, and I encourage them to have it open in front of them when *they* are studying, and to keep it by their sides for reference during rehearsal.

My advice, dear pianist, is this - go to the expense and time of making miniature copies of the score, hand them to your partners - and suggest that they go through it, and perhaps even mark on their part the sections where they have the lead, or the sections where they have not (depending on the instrument). You will definitely encounter resistance to this, but if you desire a better end result, these actions are necessary.

It is absolutely essential that each player knows where the action is at all times, and adjusts his or her tone and dynamics accordingly. Even if all the parts show a similar dynamic marking, there may be some instrument which has the main action, and the other instruments should adjust their tone and dynamics accordingly. Max Rostal, the famous teacher of the Amadeus Quartet, wrote a very informative book entitled "Beethoven: The

Sonatas for Piano and Violin - Thoughts on interpretation". There he says: "...There are differences between a leading thematic piano, a contrapuntal one, and finally an accompanying one..."

The subject of piano loudness often elicits silly statements, such as: "How can we possibly compete against such a huge instrument with our little one?" - as if size of instrument has any relevance to the volume or audibility of the sound produced. I ask you - which instrument, when it is playing, can be heard above all others in the orchestral texture? The piccolo! And we all know that the violin, when playing forte high on the E string, can cut through any cacophony of sounds like a hot knife through butter. And if size is relevant, then why does the violin sound louder than the double bass? I rest my case on the irrelevance of physical size.

You will often be told by string players and wind players that they cannot really play pianissimo - that their instrument is not really designed to do so - that the tonal quality will disappear if they do - that *mp* is about the lowest they can get down to. This is a smoke screen to cover their inadequacies. Listen to the great performers, and how they are able to get a wonderful pianissimo sound without loss of anything, except volume. If they never try, they will never succeed.

Counting

Tell me, my dear fellow pianist, have you ever heard any of your chamber music partners count the beat out loud for the benefit of the group? I haven't. It always seems to be initiated and done by the pianist. Why is there such a reluctance for them to volunteer to count aloud when the group is in trouble? They are generally grateful when, in desperation, *we* do start counting, but do *they* ever do it themselves? No! Mind you, I can understand that wind players may have a problem counting aloud, but what's wrong with the strings? The most I have ever seen them do is tap their foot - an awesome sight when examined from a distance, with multiple feet tapping the beat, out of synch with each other.

So, the responsibility for maintaining order always seems to fall on our shoulders. *We* are expected to play handfuls of notes with both hands, while checking the score for what the others are doing, and counting out loud to try to keep the house in order. And when we call a halt to the proceedings because of a lack of togetherness, there is often a feeling of resentment on their part? As if to say: "Why stop it, I didn't notice any problems. I was OK!"

And you may also have noticed that, in works without a piano, they tend to stop less often. Why is that?

Because they are often oblivious of what the others are supposed to be doing. Often, the only time *they* find out they have been out of step is when they don't finish together.

Yes, *we*, the pianists, are the ones ordained to keep the order. A significant responsibility, and one not well appreciated by *them*.

It's so easy to play the piano, compared with my instrument !

Another beauty! True, if *we* hit a key, and the piano is in tune, the correct note does emerge. Alas, this is not the case for them - *they* have to search for it, often with mixed results. That difference definitely makes our life easier.

But think of a few other aspects of relative difficulty. For example, all of them focus on one line, one note at a time. If *we* only had to play one note at a time, piano playing would be a breeze. Unfortunately, we are asked to play handfuls. *They* shudder when they see a double stop (the strings) - *we* breathe a sigh of relief when there are only two notes to play. "Oh, horror!" they cry when the notes are above the staff. We handle them above and below the staff with nonchalance. "Oh, it's up in the treble clef!", the cellist cries. *We* are asked to handle different clefs in different hands at the same time.

What about the sheer number of notes we have to cope with? *We* will have a book, *they* will have a couple of pages. The first page of the score of Mendelssohn's D minor Trio has 377 notes for the piano, and 38 and 50 for the Violin and Cello respectively. The second page has 283/48/42 - and so it goes on. In Schubert's "The Erl King", the pianist plays 703 notes before the singer even starts, who then proceeds to sing 335 notes for the whole work - an overall ratio of 1 to 16.

Think of the relative difficulties of sight reading, when we have to assimilate all the notes, in both hands, whilst keeping an eye on the score to ensure that some togetherness is maintained.

"Aren't you lucky that you do not have to cart your instruments around?", *they* say. True, but the down side is that *we* are therefore forced to play on foreign instruments, most of which are of poor quality. Even if the quality is acceptable, the touch is different, the pedals work differently, the sound quality is different - all that takes adjustment and concentration. Ask them if they would like to play a different instrument for every session of a Playing Day or Music Camp? To them, provided that the piano has a reasonably nice

case, black and white keys and a couple of pedals, it must be OK. Why complain? This reminds me of the time the Trio Slav was invited to play at the home of a prominent personality. That same individual had a recital at her home some months earlier by one of the Sydney Piano Competition contestants. I therefore assumed that she had a reasonable piano, but, to be on the safe side, I decided to check it out. It turned out to be an absolute wreck of an upright. I queried her about the earlier recital, and she told me that she, of course, had a grand piano brought in for that occasion. "But this piano will surely be good enough for Piano Trios", she said. Needless to say, I disagreed with that uninformed comment, and the lady had to bring in a grand piano to make the concert happen.

The Pianist - Partner or Accompanist ?

This question is especially relevant to duo work - ie a piano with some other instrument or a singer. As Gerald Moore quotes in one of his books: "The popular conception of an adequate accompanist is that of a quiet, modest individual of undoubted sobriety, neat but not gaudy, seen but not heard, an affable automaton, obediently following the soloist and oozing sympathy, admiration and discretion from every pore."

The popular notion is that the title of "accompanist" is a brand signifying that the owner is of a slightly inferior caste - perhaps a failed soloist?

This notion is reinforced by the physical arrangement on the stage of "soloist" and "accompanist". The standing singer or instrumentalist is plonked in front of the sitting pianist, sometimes completely obliterating the pianist from view. I have no idea when and how this weird arrangement began. I remember seeing an old film of a concert in the early 20's where the violinist stood at the foot of the open grand, in full view of the pianist and audience. It seemed to me to be a much better physical balance, and certainly providing better eye contact between the performers.

Think of the Mozart Piano & Violin Sonatas, written for Piano with Violin accompaniment - maybe the violinist should stand behind the pianist? Why are they not billed as Bloggs pianist, with Shmoggs violinist / accompanist? What about the Beethoven Piano & Violin Sonatas and the ones for Piano & Cello? Generally, except for the few written by virtuosos (Wieniawski, Sarasate, Paganini and the like) where the piano accompaniment is practically irrelevant, the piano parts are of significance, and often harder to play than the other part. And yet, at the end, the "soloist" bows, the pianist often remains seated, demurely unobtrusive, until the "soloist" perhaps

deigns to point to his/her accomplice with a regal, but curt gesture.

Back to Gerald Moore: "No good composer writes an accompaniment as an afterthought, for it must be the basis of the whole musical structure. Any piece of music with a poorly written or played accompaniment is a failure. In really fine music, he must see that there is a proper partnership between the two parts ... because he owes it to his partner ... and, above all, he owes it to the composer."

I always think of duos as partnerships, and I believe they should be labelled as "duos". They are a most satisfying form of music making, if neither acts as soloist.

Summary

So, with the whole litany of trials and tribulations which a chamber music pianist must endure, why do we still bother about venturing into chamber music at all? Well, because there is some great music written for chamber music with piano - and because we are needed to supply all the necessary harmonies and additional musical

colour and texture to the works - and also because, without the piano, there would be a lot of unaccompanied violin, cello, flute, clarinet etc. playing, and we all know what a sad state of affairs that would be, both for the soloists and the listeners. And, finally, because group music making can be a such a fulfilling experience.

So, my dear fellow pianists, sit up straight and with pride. *We* have the most complete instrument, the most notes to play, we are the only ones who seem to know what is happening in the work, and we therefore have the greatest responsibility to keep the house in order. And if this article helps you understand the motivations behind the unjustified maligning campaigns, you will be more adept at handling them.

And if you are ever accused of playing some wrong notes, just use Algernon's famous line from "The Importance of Being Earnest" - "I don't play accurately - anyone can play accurately - but I play with wonderful expression. As far as the piano is concerned, sentiment is my forte."

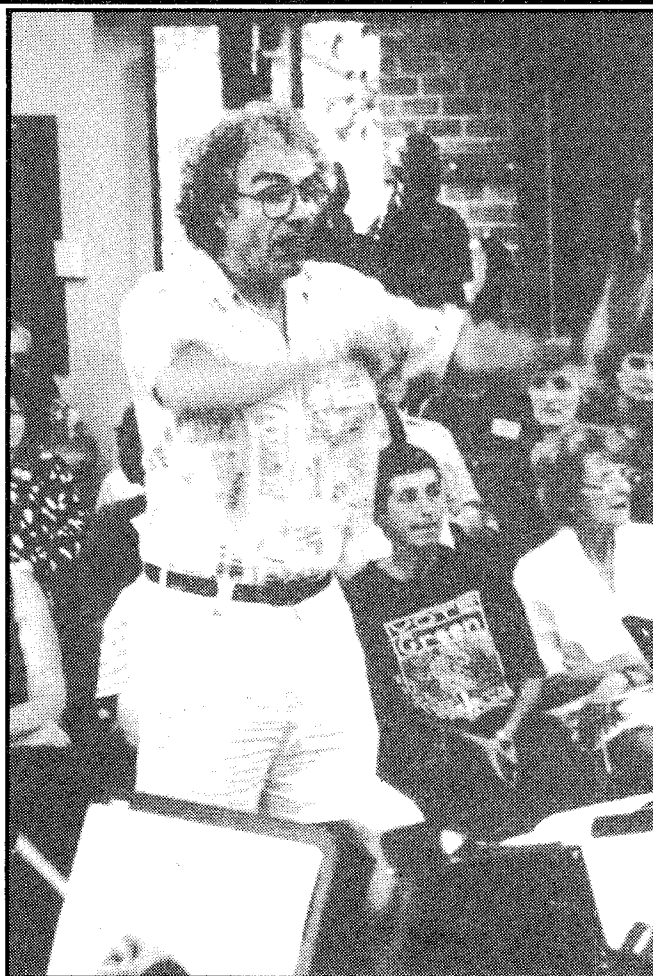

Con Spirito - Chris Bearman at Woolongong 1998
"Give it all you've Got"

Black & White Photo - Marjorie Hystek

THE PLAY OF DANIEL

by Eva Griffith

In 1958 the New York Pro Musica presented the thirteenth century musical drama, 'The Play of Daniel', the first performance since the Middle Ages.

In 1961 the Newman Association and the Guild of St. Pius X gave the first Australian performance of 'The Play of Daniel' in the Crypt of St. Mary's Cathedral, using the edition for modern performance by Noah Greenberg from a transcription by a Benedictine monk, Dom Rembert Weakland.

In 1960 I was working at J. Stanley Johnston's Music Shop in George St, Sydney. One day a friend, Pat Quin, came in to see me. She was at that time music mistress at North Sydney Girls' High School. She was a fine recorder player, singer and pianist. As we chatted over the counter I told her of a new recording that I thought she might find interesting. It had just been released. She could return it if she didn't like it.

A few days later she came back filled with enthusiasm, plans already forming in her mind to stage 'The Play of Daniel' in the newly completed Crypt of St. Mary's Cathedral. She insisted that I must be involved as I had introduced her to it.

I'd been playing the oboe for a bit over a year. I can't say I'd been learning the oboe as I'd only had three lessons when my friend, Peter Randall, who sold me the oboe and said he would teach me, left Sydney to join the West Australian Symphony Orchestra. I tried to find another teacher but the only one available at the time was Ian Wilson at the Con, who was unable to take me. Perhaps he already had too many students. So I was not very confident about my ability to do justice to my part in the 'Play'. I was to play the part originally written for the rebec, an early type of violin, which Pat had not been able to procure for the production.

In a newspaper interview at the time, Pat said 'Trying to persuade people it could be done, was difficult.'

Beside finding musicians, singers, choristers and actors, Pat was determined that wherever possible replicas of mediaeval musical instruments would be used. In a remarkably short time, she was able to gather together the forces that produced a lute, an auto-harp, a natural trumpet and recorders; a set of rare handbells, a century old; genuine Arab finger cymbals that were tracked down after a conversation overheard in a record bar; an 85 year old Irish minstrel harp brought from Ireland in 1958, its origins going back to the Middle Ages. A small portative organ was constructed specially for 'The Play' by well-known organ builder, Ronald Sharp, builder of the then new organ of St. Mary's Cathedral. Using pictures of the mediaeval instrument as his only guide, the portative organ had hand-operated bellows, a fifteen inch keyboard and twenty small wooden bourdons (soft organ stops).

There were a few modern instruments such as my oboe, (which was actually a very old instrument made by the Hawkes Company before it became Boosey and Hawkes), a viola, bagpipes, zither and an array of percussion instruments.

The impressive cast that Pat was able to recruit included at least three whose names have since become very well known. Winsome Evans played recorders. She is now the director of the Renaissance Players, which specialises in music from mediaeval times. Germaine Greer, who needs no introduction I'm sure, played finger cymbals. Nigel Butterley, now one of Australia's best known composers, sang three different parts, Habakkuk, one of the Chamberlains, a member of the court of Belshazzar, and later, a soldier in the army of Darius.

Then came the rehearsals. First sitting and reading from the beautifully presented scores. Eventually we would have to learn the whole score off by heart. It would have been completely out of the character of the 'Play' to be reading from the music, especially as there were many processions up and down the aisle through the audience. During the

performances we would not be able to wear anything that belonged to the 20th century such as spectacles or watches. The meticulous attention to detail that Pat, as the Musical Director and James Lang, as the Producer, demanded from everyone involved resulted in comments from reviewers, such as: . . . 'the costumes, even under the closest scrutiny, were convincingly in period'.

There were altogether three seasons of 'The Play of Daniel', two in 1961 and one in 1964.

During one of the performances in August, 1961, Father Ronald Harden, director of St. Mary's Cathedral Choir at that time, recorded a complete live performance. It was transferred to L.P. and released by Philips. In a review the Sydney Morning Herald Music and Drama Critic (name not acknowledged), wrote, 'It is happy news that something tangible will remain of the James Lang / Patricia Quin version of 'The Play of Daniel' . . . the quality of the disc is exceptionally good. . . and holds its own as a performance and recording to be enjoyed for its own sake.' It was also filmed and shown on ABC-TV but I cannot remember when.

The critics were unanimous in their praise. Julian Russell, well-known critic at that time, . . . presented with impressive artistry . . . The players, entering from time to time in procession through the audience, gave the whole production an atmosphere of unique immediacy. . . the lighting was spectacularly effective, the groupings picturesque. . .'

R.C. (Roger Covell ?) 'The sound of a trumpet ringing through the crypt of St. Mary's Cathedral

last night was once again a summons to the most impressive musical and dramatic experience that Sydney has fashioned out of its own resources within the last year . . . the manner in which Robert Moore's shifty-eyed Belshazzar sat on his throne, even in the way he held his sceptre he might have been taken bodily from an illuminated missal or a stained-glass window.'

‘. . . This church opera has retained under the joint supervision of James Lang and Patricia Quin all the vivid dignity and unforced directness that put its earlier season among the finest achievements of musical drama in this city. . . as the last of the procession fades into the night outside there is sheer magic in the air.’

C. M. Prerauer, 'The Sun' . . . 'Shining through the Sydney theatrical scene like a minor miracle, . . . It is leaving not only all amateur but most of our professional shows in the shade with its effortless fusion of singing and staging.'

The Deller Consort gave a performance of 'The Play of Daniel' at the Adelaide Festival in 1964. According to R.C. at that time, 'In almost every detail that matters, the (Adelaide) festival production of 'The Play of Daniel' is greatly inferior to the much more modestly financed Sydney season . . . fussy irrelevancies of production . . . melodic rhythms are generally slacker . . . the inevitable comparison with the James Lang - Patricia Quin version in Sydney only confirms what a truly remarkable achievement that was.'

The 'Play of Daniel' was without a doubt one of the greatest experiences of my life.

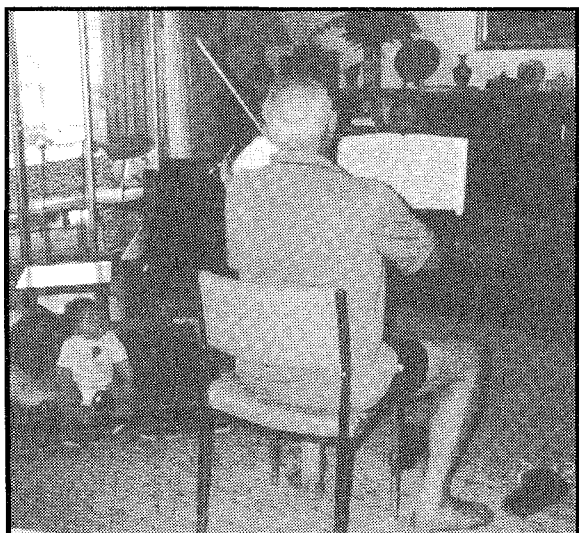

Passing on the Torch or whatever

Photograph Ann Korner

Secret Confessions of an ex-President

Author: Rod Tuson. Censor: Alexandra Tuson

Note to editor : This should be in the **special sealed section** of Ad Libitum. All references to individuals are meant to be interpreted as fictional and generalizations. Neither the author, the censor nor the Society accept any liability whatsoever regarding any of the matters contained herein.

Due Procedure

It has been said that "justice not only has to be done, it has to be seen to be done". In the special case of a president of the amateur chamber music society, these priorities need to be reversed. It is far more important that justice is seen to be done than actually done ! Perception is nine tenths of the law. This principle I followed to the letter during the few years I was president, and it worked like a charm.

A few years ago, at the all-important annual general meeting, I had a short discussion with the then secretary, only to learn that there were no minutes extant for the previous year's AGM. As you all know, the first item on the agenda of any AGM is that the minutes of the last one are read and accepted. Well, this secretary, having been schooled in the position of President for some years, had learned the adage regarding justice being seen, rather than actually being done. The AGM proceeded in a most orderly and efficient manner, with the said secretary "reading" the last years minutes from a totally blank page (or was it the cello part of "The Secret of Susanna"). Whatever. The members were none the wiser, and the minutes for the previous year were duly accepted and hastily written up later in a manner which represented a mixture of the actual facts and what had been "read" to the next year's meeting.

If that is not enough, in a newsletter from the Victorian society a few weeks later, they confessed to having to delay their annual general meeting because they could not find the minutes of the last years AGM. (Poor naive dears !) You can imagine the mirth among the committee members privy to our own deceptive practices !

Mirth at other's expense

I have to confess to enjoying a thorough chuckle which, if it weren't for the fact that I am extremely fond of the individuals concerned and hold them in

the highest regard, would render me liable to dreadful criticism (which might come anyway). I recall a time in our beloved Wollongong during a morning tea break in the vestibule of what was euphemistically known as "the long gallery" in the main grounds, and choked with weird arty things amongst which the dulcet strains of Mozart seemed dramatically anachronistic. One of our relatively youthful members was asked the whereabouts of one of our senior citizens (a string player who, through many decades of juggling the wooden monster under his chin, had developed a pronounced stoop, made more noticeable by a strangely raised left shoulder). The response was a defeating "I've no idea", but this wit, as he climbed the stairs in the large public area, immediately struck a pose which replicated, unmistakably, the physical attributes of the missing player, saying "I'll keep an eye out.". The mimicry was so accurate, both individuals having a similar tall gaunt, figure, that stifling the mirth was a Herculean effort.

We all show our Achilles heel in Wollongong - nay, even our tutors. One of our most loved has a tendency to become more irascible than usual when totally exhausted (which must happen to them often, as to us, as we struggle to survive the rigors of Wollongong). A few years ago members were invited to apply to play a movement of their favourite concerto with a backing orchestra of some of the other members. A golden opportunity ! A certain aged but fine violinist was to play a Mozart Violin Concerto. As he had a tendency to become lost (geographically - never musically) he was late to this session. Well, the conductor, overtired and cranky as a result, was lecturing the orchestra on the ill manners of a late soloist. When said star appeared, only to receive similar flack from the conductor. Quick as a shot, the soloist replied to the conductor "well, you could have started without me, I have the first 14 bars rest!" There's no answer, is there?

The Hole in the Program

The first time we had "the barbecue" in Wollongong, all the feeding was over well ahead of the next programmed session. Comes the question from some poor naive soul : "What do we do next?" Tired administrator, quick as a flash: "The washing up!" A good time was had by all, many hands made light work, entertained by an ad-hoc group for whom there presumably weren't enough dishcloths, and many friends were made around the sink - where else?

The Secret Register.

Why do the grouping arrangements work so well (on the whole) at playing days and Wollongong, when the basis on which the talents (or otherwise) of the players is defined by a self-assessment? The answer, of course, is the secret register. All you meek and mild players who are actually E and call yourselves C have long since been twigged. Likewise, those who have inflated opinions of their talents have also been evaluated by those with whom they have played. It sounds grubby, but the self-assessment questionnaire has fuzzy borders. I recommend doing it twice, once putting the most optimistic interpretation on your answers, and once being totally brutal with yourself. Somewhere between the two extremes you will find your true rating. If they are widely spaced, you need help. Ask for help from one of your closer chamber music friends to whom you feel comfortable about confessing your innermost insecurities! Also, it is worth doing every year or so, because the standards of all of us wax and wane depending on how much playing and practice we are doing, and if we are having lessons. It's amazing how our standard slips when ill-health or the pressure of work (or committee duties) erodes playing and practice time. Disregard any results you get when you are exhausted or unwell.

Why is the ACMS so Successful (or is it) ?

The main reason (for our success) is a continuous sequence of energetic and brilliant committees who have kept the founders' (Irwin Imhof, Nils Korner, Judy Mitchell) vision in mind while not losing sight of the needs and aspirations of the membership at large. This vision (or in modern business jargon "mission statement") was embodied in the

constitution drafted by John Pinn and Stephanie Hicks. The marketing gurus might judge performance by the membership numbers, but is this a true measurement of achievement of the objectives? There are hundreds of former members who have quietly formed stable neighbourhood groups which are self-sufficient and no longer need the society's services. Our brother societies in other states are testimony to our success, each being flatterers by imitation, if imprecisely of the original ACMS.

Committee service - Bliss.

Serving on the committee is not just plain hard slog. Far from it - the work is rather intermittent and very satisfying. The results of a job well done - the look of immense satisfaction on those players who are transported with delight at a playing day or Wollongong is a most satisfying sight to behold for one who has put some effort into achieving such satisfaction. Apart from that, there is great fun to be had in some of the organizing, and, if you are of a slightly selfish bent, one can be especially careful with your own groups when working on a grouping session. There's a tremendous buzz to be had by debating with great minds the merits or otherwise of some committee decision and planning innovations which can be tested and evaluated before they become part of the formulae for continued success. It's worth spending at least a year on the committee just to get some of your ideas aired and maybe trialled, and to find out what little bits of magic make the society tick.

Our "Core Business"

This is a plea to concentrate on satisfaction of members. While it is right and proper for new committees to try new initiatives, it is important to focus on customer (members) satisfaction.

The Group Manager

Consider a quartet string, wind, mixed, whatever - four players. This has been set up and arranged using the member register. What happens when one player can't turn up on the appointed day? A series of phone calls must be made. Two of the others can come on Wednesday instead of Tuesday, but the third can't. Another three calls ! Another three to

confirm the amended day ! Never under-estimate the value of the group organizer. He or she runs up a phenomenal phone bill just making sure it will all happen. There is a lot to be said for the regular weekly or fortnightly gathering, cancelled only at the risk of incurring the wrath of one's fellow players. The person responsible for organizing the meetings should at least be given everyone's full understanding and appreciation, and should also be forgiven almost any failings, due to the huge extra amount of work and expense he or she has accepted on behalf of the other members of the group.

A word of warning. Let those who wish to arrange larger groups for playing outside playing days be warned. The number of phone calls necessary to arrange a group is mathematically linked to the size

of the group (repeated in the event of a no-show as in the example above). The formulae works like this (if you are lucky):

Group size	Number of phone calls
1	0
2	1
3	2
4	6
5	24
6	120
7	720
8	5040

The octets are really only feasible on playing days, when there are "captive" players! The many mathematical among us will recognize the formula as factorial $(n-1)!$

FANTASY FOR CLARINET

by CAROLYN LA MOTTE

When as a child music entered my life, all I could see was the clarinet. I used to sit, my chin resting on my hands, eagerly staring down from the Town Hall balcony as the Sydney Symphony Orchestra introduced me to sounds that sent my spirits soaring.

When I suggested to my parents that I wished to learn the clarinet, there was a certain air of scepticism. This from a girl who had convincingly persuaded them in past years of her mission as a writer, an actress, a tennis player, a psychiatrist, a new age teacher. Music had played no part in my upbringing besides the hit parade, poking my fingers in my ears when entertained at school by visiting sopranos and walking out on Fantasia when all the background noise interfered with the entertainment.

My choice of the clarinet sat comfortably with my parents. They were products of the Big Band era and Artie Shaw, Benny Goodman and Pete Fountain had long been idols. When my father first took me to the Sydney Conservatorium to inquire about lessons, the administrative staff seemed to be quite unaware that I was on a mission from God. They unemotionally assigned me to a teacher with a time and a date and talked about topics like fees and the amount of notice to be given if I was going to miss a lesson.

My assigned teacher was Thomas (Tim) White. He was the retired principal clarinetist of the Melbourne

Symphony Orchestra, a noted clarinet authority, having probably the largest collection of different types and antique clarinets in Australia, and a dear man. From the first moment we met he was to me the Archangel Gabriel. I glowed with excitement throughout my lessons and spent the intervening week in nervous anticipation of the event. And of course I practiced. This was my thing. The thing I wanted to do. The thing that made me special.

Tim White was an old and a sick man. He had an incredible stutter, but he also had an enthusiasm that matched my own youthful joy. Perhaps because he didn't have too much longer to live, he didn't seem to want to bother much with technicalities. He was going for the sound. I had barely achieved the upper register when he produced the Mozart Concerto; Gran Partita; Quintet; Weber Concertino. "Feel it sing it; love it", he advised and how I did. "Be extravagant in your expectations with music", he said. "Revel in the rewards".

The big thing I have learned from music is that it is the art form of the now. The performance you are giving is a reflection of yourself at this exact moment in time. You can't go back and erase the interpretation, cancel the ideas. This is it! This is me now ! Hear what I say as I converse with Mozart. Every time I play I am touching greatness. And the clarinet ? What a sound ! What expression ! What beauty ! What luck !

MUSIC AS A RECREATION

Solomon Bard

*"The aim and final reason of all music is the
glory of God and the recreation of the mind"*

(J. S. Bach)

We live in a world of sounds. From the earliest times, sounds played an important part in man's life. Nature's mighty sounds filled him with fear and became a symbol of supernatural power. Primitive man used sound to express his feelings, and through sound found his way to music. Music was born in that dim antiquity from man's instinct to express himself in singing and dancing. It became part of his many activities; it enabled him to express his love, hate, warlike instincts, and his belief in a supreme power.

The importance of music in man's life is at least in part due to the power it has exercised over the human mind since the earliest times. True, this power has weakened as man has become more civilized, but even today there are many examples testifying to the power of music. It exerts its effects upon an individual as well as upon the masses. It may rouse the noblest emotions or the basest instincts.

Consider, for instance, the two works of a totally different merit, such as Wagner's *Tristan*, and, more recently, the song *Gloomy Sunday*, and the wave of melancholia and suicides these two have caused; or take the *Marseillaise* which had such a profound influence during the French Revolution that it has probably left its mark on history.

It is necessary, however, to say something about the purpose of music. It is simply the purpose of those who come in contact with it. The composer has the urge to create and find expression through music. The executant may also wish to express oneself, or simply to make a living. There are some, very few I hope, who are so insensitive to music that to them it is merely an acoustic phenomenon, in which they find neither pleasure nor satisfaction. But there are many others to whom music is neither the greatest purpose and dedication in life, nor a mere acoustic phenomenon, but a Recreation - a source of enjoyment in their leisure hours.

In the accepted usage, the term recreation means a pursuit of some interest or occupation during leisure hours, as distinct from one's main or whole-time occupation. It is as a recreative activity, however, that music, and other forms of Art, fulfil their final aim; for a book has to be read, a painting to be seen, and a

musical composition has to be heard to achieve its end. The creative work has to meet another mind, in which it is "re-created", not necessarily according to the author's intentions.

People who use music as a recreation may be roughly divided into three categories"-

1) people for whom music may be said to provide an "escape". I use this term not in any Freudian sense; an escape which music provides is not from an unbearable reality or an unattractive life, but simply into a different and refreshing experience.

2) people for whom music is an absorbing form of Art, one that is nearest to their level of perception, or most easily communicable. They have a strong urge to listen to or perform music, and to learn to appreciate an ever-widening horizon of musical composition. Their appreciation of music is intelligent and may be to some extent analytical.

3) people who simply enjoy music, be it a melody or a rhythm. They usually find their own particular taste in music, which they do not bother either to analyse or to develop.

Music fulfils its particular purpose for all these people, and makes their lives more complete. How does it achieve it? I believe the answer to this lies in the basic function of music, which is to take the listener into a world of fantasy created by the composer. It is even likely that when the listener returns to reality, his attitude to it may be changed. It is a common experience for a series of images to be evoked in the mind of a listener. This property of music is most clearly seen in what is commonly called "programme music" - music which has attached to it some literary or pictorial label. There are well known examples of this music, such as the "Moonlight" Sonata, the "Tragic" Symphony, or the "Apassionata" Sonata.

As a recreative activity, music is either performed, usually by amateur musicians, or listened to. One person may be, of course, both a performer and a listener at different times. Let us consider the listener first. The uses to which he may put music are many.

He may simply use it as a background noise, as pure excitement, or as an aid to meditation, none of these requiring knowledge of music itself or demanding a study of it as an art. He may, on the other hand, use music for widening his understanding of intellectual values. Whoever sees this purpose in listening, will feel the need of more education and of greater appreciation of music. There is no doubt that some degree of appreciation will enhance the enjoyment derived from music as a recreation.

Anyone who regards music as a serious and worthwhile recreation, and wishes to get the maximum of enjoyment and satisfaction from it, must try to develop an intelligent appreciation of it. It cannot be done quickly. A great deal of listening as well as a certain amount of reading is required.

Listen to harmony and counterpoint used by the early composers such as Palestrina and compare them to those of Bach, Mozart, Beethoven and Brahms. After listening carefully and often, he will come to realise and enjoy the essence of harmony, in the rich combinations of Beethoven and Brahms, as well as in the strange combinations of Stravinsky.

A discussion on music as a recreation would not be complete without saying something about performing, or as I would call it, making one's own music. Although the majority of people who use music as a recreation are listeners, there are many who are also performers. There is no doubt about the great value of music, as a recreation, which comes from playing. Even though only few can become good performers those who are not, can get much pleasure from playing an instrument, or singing, especially in the pleasant and familiar surroundings of their own home.

Gustav Holst the famous British composer, once said that if a thing was worth doing at all, it was worth doing badly ; this, of course, applies to music-making at home. Unfortunately, today people have grown afraid to

perform badly even for themselves let alone as audience. True, great music, brilliantly performed, can be turned on by a twist of a knob, but it is no substitute for the effort from which true experience comes. A great part of the mysterious appeal of great music is something hidden, not in it but in ourselves.

Of all possible instruments that the music lover of any age - for it is never too late to learn -may choose to take up, there is none more rewarding than the piano (Frank Howes once called it the most patient domestic animal), for it is both itself and all instruments in one. A great deal of enjoyment and deep satisfaction may be had by sitting at the piano and going over Bach's partitas, however inexpertly, for one's own entertainment. Far too many pianos are standing idle because of a radio, a gramophone, or a television set.

Has music any contribution to make to the making of man and his character? I believe it has. Plato judged music according to its moral effect, and made it serve a narrow purpose in the interests of the Republic. Aristotle enlarged on this by regarding music as a balancing force in human emotions. Today, I believe, we can regard the contribution of music as a more active element. Music is not a mere emotion or still less a frivolous decoration of life. The aesthetic value of music as an art is undeniable. More than this, those who train and increase their appreciation of music, as a recreation, or a pastime, increase their knowledge and discrimination in general, and achieve not merely more pleasure, but a greater power over their environment. If the aim of ideal education is to produce good people, then music must be a part of ideal education.

Music has many facets and can give many answers according to the purpose for which it is used. Between a dance song and church hymn, from a quiet lullaby to a rousing march between a gay air and a deeply intellectual symphony, lies its infinite variety ; but to those who love it as a recreation, it has a common meaning - the awakening of all dreams and yearnings.

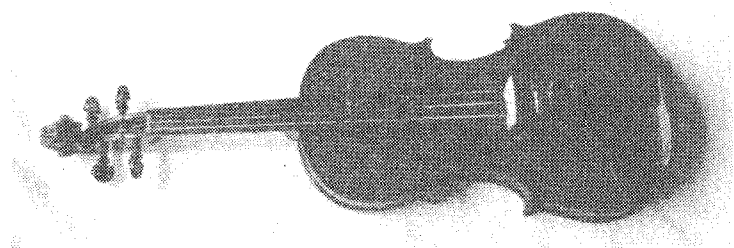

PROTECT YOUR MUSIC - KEEP IT BEAUTIFUL !

PETER & FELICIA MITCHELL

The more you play, use and enjoy your printed music, the more likely it is to succumb to wear and tear, and the ravages of time. However, by spending a small amount of time and effort, it is possible to provide your music with covers which will greatly extend its useful life. The method we have used to do this is described below. (It is a good idea to have a practice run before attacking your favourite music.)

You will need :

- A2 sheets of thin cardboard (available from newsagents)
- Linen thread
- Suitable self-adhesive tape (difficult to get, current supply Scotch Super 250 packaging tape from Stationery Wholesalers, Alexandria)
- Darning needle

Instructions :

1) Cut 2 covers from each A2 sheet as shown, making the height of the covers the same as that of the music. Leave the extra width for the moment.

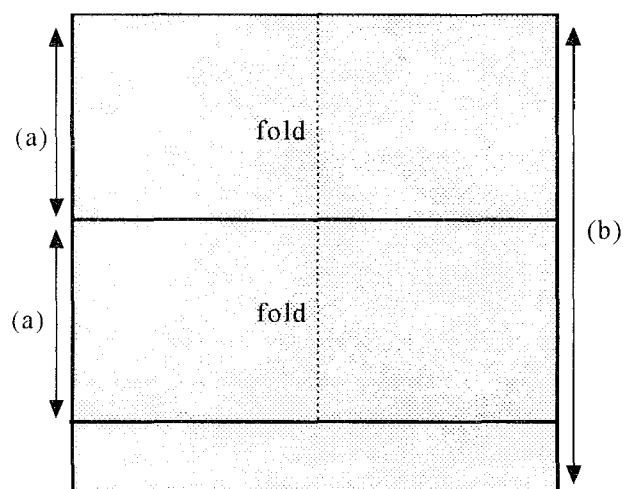

where:

- (a) height of the music
- (b) length of A2 sheet

2) Fold the cover in half along the centre, and apply the self-adhesive tape to the outside of the cover, centred on the fold. Fold about 2 cm back onto the inside of the cover. Make sure the tape is aligned accurately before applying, as it sticks immediately.

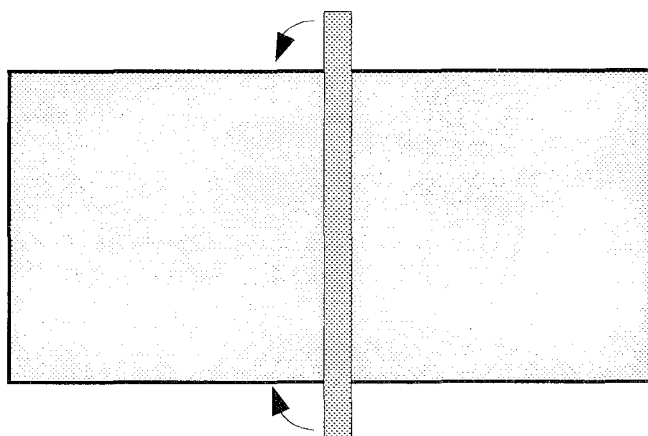

3) Remove the staples from the music.

4) Sew the cover to the music with linen thread, making 4 holes along the centre.

5) Tie the linen thread firmly.

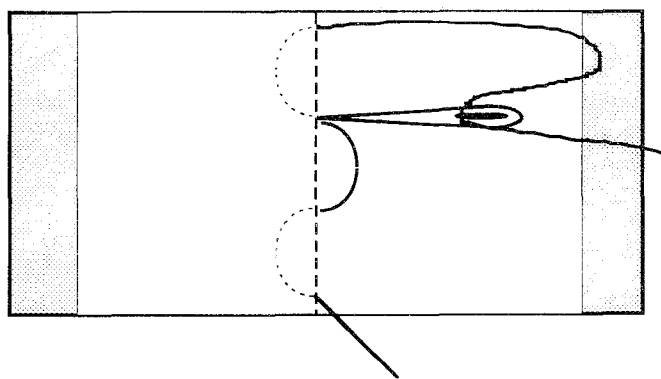

6) Mark the cover with a pencil for cutting off the excess width with a guillotine or scissors.

